

Vanguard Series 2V-M-TD



Features:

- Modular design** allows for later upgrade.
- Easy Maintenance** all components and inter-connecting pipework removable from the front.
- Full flow Path** eliminates dead space to a minimum.
- Springless Valves** reduce particle generation.
- Tied Diaphragm Regulator** provides positive shutoff.
- Manual RIV** for Regulator protection during purging
- Manual PVV** for cylinder exchange purging c/w non-return valve
- LOTO** on manual valves for safe maintenance.
- Burst Disc (10 bar +/- 10%)** for overpressure safety relief

All components of 316L material with PCTFE soft goods (Vespel® available as option)
All tubing orbitally welded
All mechanical joints of the faceseal (VCR®) Type

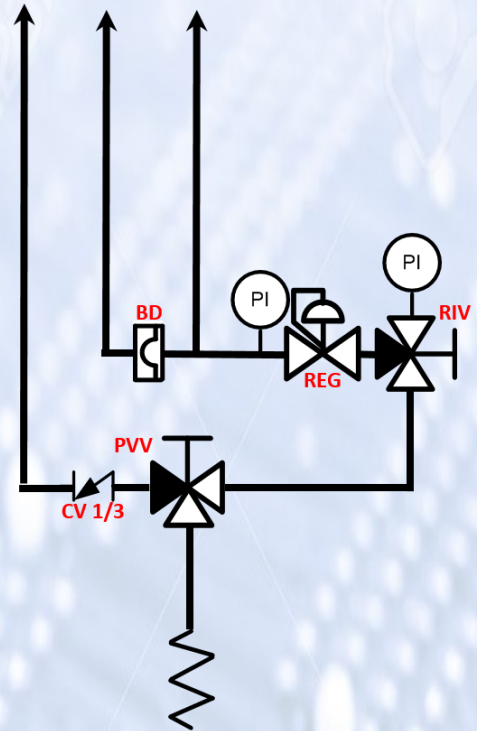

DESIGN STANDARDS

- Conforms to Pressure Equipment Directive (PED) 2014/68/EU
- Helium Leak Tested to 2×10^{-9} atm-cm³/sec
- Conforms to SEMI S2 standards
- Maximum inlet pressure 3500 psig (238 bar g)
- Maximum outlet pressure 100 psig (6.8 bar g)
(250 psig (17 bar g) available on request)

Additional Enhancements

Cylinder gauge to Transducer

Allows for Low cylinder alarm when used in conjunction with the GCT4-S controller.

Outlet gauge to transducer

Allows for High Outlet Pressure alarm when used in conjunction with the GCT4-S controller

Manual High Pressure Leak Test Valve with LOTO

Allows for leak testing of cylinder connection and gas panel

Manual Process Line Isolation Valve with LOTO

Allows for isolation of gas panel from process gas line for leak testing of gas panel and maintenance

Ordering information

2V - M - TD - **XX** - **XX** - **XXX** - **XXX**

Base Model

Inlet Sensor

10 = 0-1000 gauge

30 = 0-3000 gauge

XD = Transducer

Outlet Sensor

1 = 30-0-160 gauge

XD = Transducer

Option 1

LTV = Leak Test Valve

PLI = Process Line Isolation Valve

Option 2

LTV = Leak Test Valve

PLI = Process Line Isolation Valve